

NUCLEAR AND RADIATION SAFETY ANALYSIS OF DISCHARGE, TEMPORARY STORAGE AND PREPARATION IIN-3M RR LSNF FOR TRANSPORTATION TO REPROCESSING

A.Z. GAIAZOV, D.V. DERGANOV, S.V. KOMAROV, A.A. ROZHNOVSKAIA,
O.E. POLOVNIKOV

*Sosny Research and Development Company (Sosny R&D Company)
23 Bldg 1, Novocheryomushkinskaya Str., Moscow, Russia, 117218*

U.S. Salikhbaev
*Vienna International Centre, IAEA
PO Box 100, 1400 Vienna, Austria*

ABSTRACT

This paper briefly describes the procedure and equipment for handling liquid spent nuclear fuel (LSNF) of IIN-3M reactor located on the JSC FOTON site (Tashkent, the Republic of Uzbekistan).

The results of the safety analysis performed for the IIN-3M LSNF handling procedure are presented. This analysis includes the equipment media subcriticality calculations and ionizing radiation dose rates on the personnel work places estimations.

The severity of probable accident consequences is assessed and the measures to mitigate the consequences are also proposed.

The results of assessment became the basis for the developed procedure safety analysis report. The on-site activities according to the procedure considered were successfully completed in 2015.

1. Introduction

Although solution reactors with liquid nuclear fuel operate both in Russia and abroad up to the present moment there has been no handling technology considering irradiated liquid fuel preparation for transportation and radiochemical reprocessing.

The Procedure of discharge, temporary storage and preparation for transportation of LSNF (uranyl sulphate water solution) from IIN-3M reactor vessel to reprocessing was implemented using unique equipment designed by the specialists of Sosny R&D Company. The procedure of work implementation was also developed by Sosny R&D Company.

Within the implementation framework Sosny R&D Company specialists successfully solved a number of scientific and technical problems such as:

- design of the special equipment for LSNF discharge from the reactor into temporary storage canisters;
- design of the equipment for LSNF discharge into the transport canisters;
- design of the equipment for loading transport canisters into SKODA VPVR/M cask.

Besides a procedure and equipment for accepting and handling canisters with LSNF at the SNF reprocessing facility were developed.

The equipment development process included thorough safety analysis that contained nuclear, radiation, fire and explosion safety analyses, possible accidents analysis.

In September 2015 canisters with LSNF were loaded into the transport cask on the site of IIN-3M reactor. In 2015 irradiated LSNF was also transported by air to the Russian Federation and successfully reprocessed at Mayak PA.

Technologies and procedures developed for shipment preparation and reprocessing of LSNF from Uzbekistan can be used for SNF of Russian solution reactors handling. Moreover,

the technologies can be applied to shipment of other high-level liquid waste to the reprocessing facilities.

2. Brief Description of the Procedure and Equipment for IIN-3M LSNF Handling

Handling the IIN-3M LSNF includes two stages: The first stage is LSNF discharge from the reactor into temporary storage canisters. The second stage includes reloading the LSNF into transport canisters with the following transport canisters loading into a transport packaging. Newly-designed equipment was used for discharge and temporary storage of the LSNF. The equipment included:

- a dosator;
- a vacuum pump;
- a compressor;
- temporary storage canisters;
- pipelines and valves;
- process control sensors.

The equipment configuration is given in Figure 1.

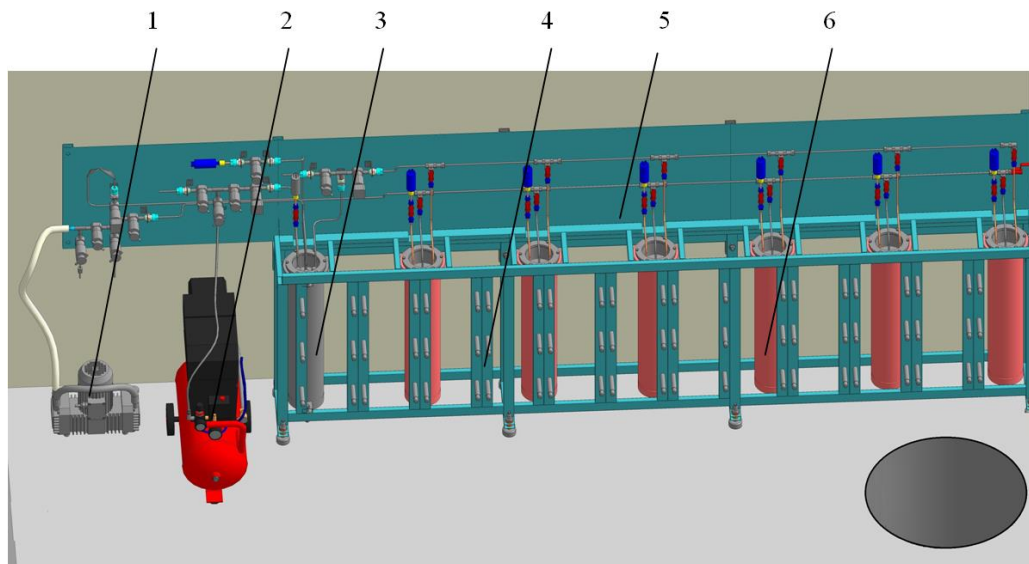

1 – vacuum pump; 2 – compressor; 3 – dosator; 4 – rack; 5 – stand;
6 – temporary storage canister

Fig 1. The configuration of the system for discharge and temporary storage of LSNF
(biological shielding is not shown)

According to the developed procedure the dosator is vacuumed and filled with LSNF. Then an underpressure is produced in a temporary storage canister and LSNF is transferred from the dosator to the temporary storage canister.

The design of the dosator and the temporary storage canister is shown in Figure 2. The geometrical dimensions of the elements with nuclear fissile material were determined assuming that nuclear safety was provided even in case of fully filled with LSNF elements. All equipment items that are in contact with radioactive media are made of corrosion and chemical resistant steel.

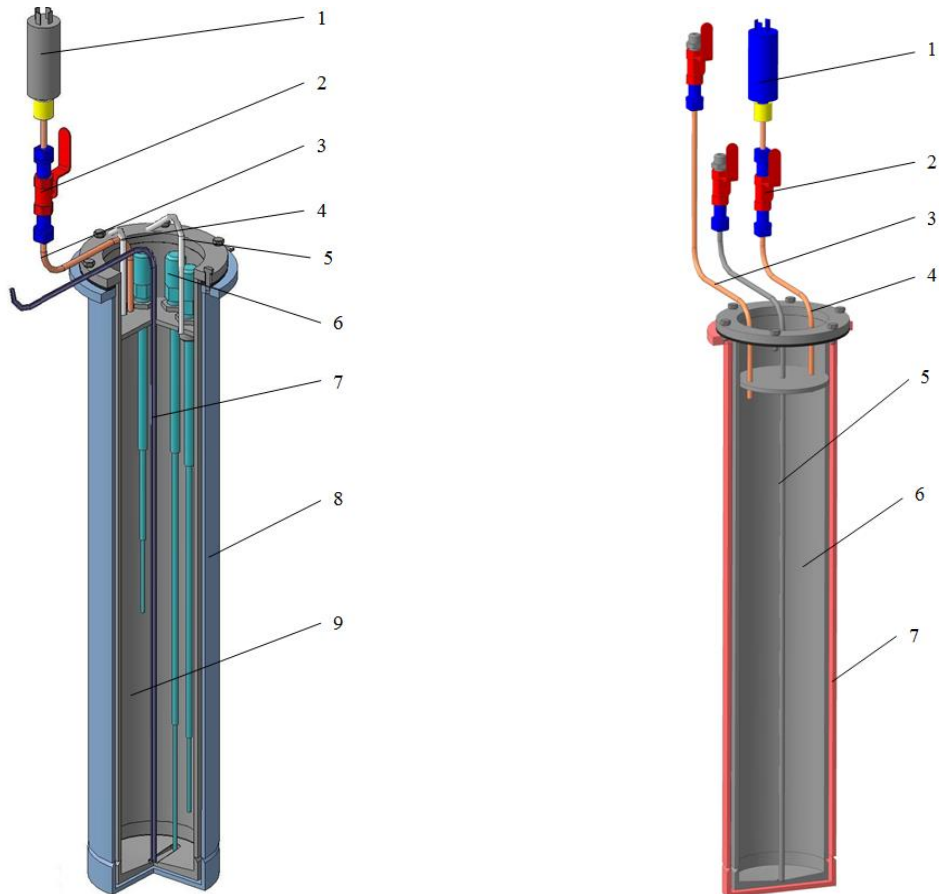

1 – pressure transmitter; 2 – gate valve;
 3 – pressure check line; 4 – underpressure
 line; 5 – LSNF loading line; 6 – electronic
 level limit switch; 7 – uranyl sulfate solution
 unloading line; 8 – external steel can;
 9 – inner steel capsule

(a)

1 – pressure transmitter; 2 – gate valve;
 3 – underpressure line; 4 – pressure check
 line; 5 – LSNF loading and unloading line;
 6 – inner steel capsule; 7 – external steel can

(b)

Fig 2. Dosator (a) and temporary storage canister (b)

The equipment has the following specific features:

- LSNF is transferred by vacuuming the equipment. This method excludes any release of radioactive substances into the environment even if the system elements lose their integrity;
- LSNF is transferred between the equipment elements via the dosator that controls the amount of the product to be transferred and prevents overloading of the equipment vessels;
- Double walls of the dosator and temporary storage canisters prevent LSNF from spillage in case the internal wall loses its integrity;
- Quick remotely operated gate and control valves allow LSNF transfer in automatic mode;
- Backup gate and control valves allow accident-free localization of a failed part of the system;
- Biological shielding minimizes radiation exposure of the personnel involved in the procedure implementation.

LSNF is loaded into canisters (Fig. 3 (a)) via a separate pipe provided in the system for discharge and temporary storage of LSNF. The procedure of LSNF loading into canisters implies vacuuming the dosator and transfer an LSNF batch into the dosator volume. The LSNF batch is also transferred from the dosator into a transport canister by producing vacuum within the canister.

A transfer cask (Fig. 3 (b)) is used to protect the personnel from ionizing radiation exposure of the encapsulated LSNF. A peculiar feature of this item is a possibility to dismantle the winch. This gives the personnel the access to the canister throat to connect the canister to the system for discharge and temporary storage of LSNF.

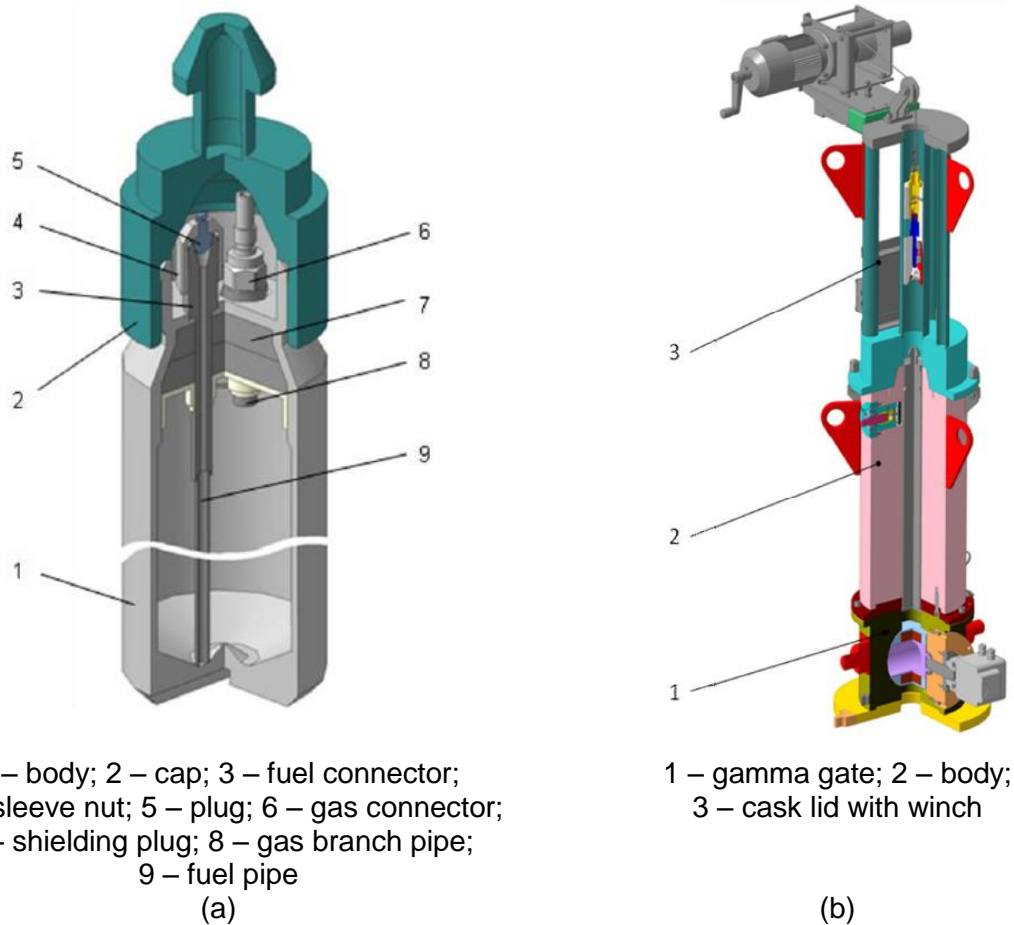

Fig 3. Main equipment to prepare LSNF for transportation: canister (a) and transfer cask (b)

3. Radiation Safety Analysis for IIN-3M LSNF Handling

The fission products localized in the LSNF are the principal source of radiation exposure for the personnel, the public and the environment during the implementation of the procedure considered. The design of the discharge and temporary storage system as well as the procedure of operations prevent the release of radioactive substances both in liquid and aerosol form outside the equipment boundaries. This allows us to conclude that the contribution of the internal exposure to the personnel exposure is negligible.

All handling operations with uranyl sulphate solution are performed in the reactor hall. The walls and the ceiling of the reactor hall are made of heavy concrete that provides required attenuation of gamma-radiation on the way of its propagation outwards of the IIN-3M reactor building. Consequently the only factor of radiation exposure for the public and the environment is radioactive substances in the form of aerosols discharged into the atmosphere from the facility ventilation.

Ionizing radiation dose rates caused by main elements of the equipment were determined in a series of calculations to predict radiation situation on the work places of the personnel and to justify sufficiency of the selected thickness of the biological shielding. The calculations were performed with MicroShield 8 software and verified using Scale 6.1.2 software. The calculation results are given in Table 1.

Equipment	Source geometry	Shielding characteristics	Dose rate behind the shielding, $\mu\text{Sv/h}$
Fuel line tube	Cylinder (length 5 m, diameter 3 mm)	Steel shell 1.5 mm thick	3.3
Temporary storage canister / Dosator behind lead shielding	Cylinder (length 680 mm, diameter 133 mm)	Lead shielding wall 80 mm thick	4.8
Canister in transfer cask	Cylinder (length 709 mm, diameter 66 mm)	Steel shell 110 mm thick	21.2

Tab 1: Calculated dose rates of ionizing radiation caused by main equipment elements filled with LSNF

Based on the assumed duration of the process operations assessed by the experts as well as in compliance with the applicable personnel arrangement (Fig. 4) individual and collective dose rates were calculated for the personnel in the process of the procedure realization. Committed individual dose rates for the personnel are presented in Table 2. This data shows that during the procedure implementation the personnel dose rates will not exceed the limits specified by the regulatory requirements.

Actual dose rates measured on the work places during practical implementation of the procedure in 2014-2015 showed acceptable range of the prediction results and measured values (the discrepancy did not exceed 10 %). Individual doses turned out to be significantly lower than the predicted values due to reduced time of operations. This reduction was achieved by numerous repetitions of the process operations during the personnel training.

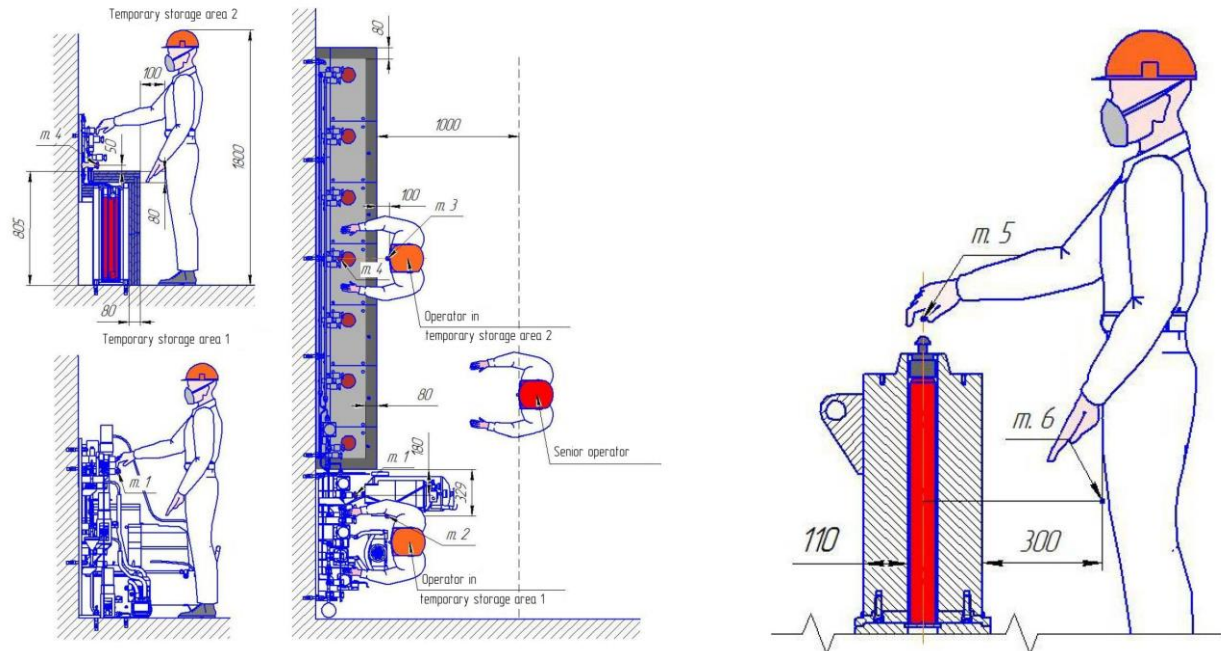

(a) activities with the system for discharge and temporary storage of LSNF

(b) handling of the LSNF-filled canister in the transfer cask

Fig 4. Personnel location during practical work

Stage	Position	Hand exposure, μSv	Body exposure, μSv	Exposure duration, h
Discharge and temporary storage of LSNF	Senior operator	41.4	41.4	10.2
	Operator	49.5	43.5	10.2
Load LSNF into canisters and load canisters into transport cask	Operator	6820.7	1016.3	78.1
	Senior operator	1228.7	955.1	78.1

Tab 2: Calculated the personnel individual doses during practical work

The activity of the radioactive substances discharged into the facility ventilation during the equipment vacuuming was analyzed to determine radiation impact on the public and the environment during the procedure implementation. The analyses of the radioactive releases included the following stages:

- determine the mass of the solution discharged into the facility ventilation system due to evaporation of residual film from the internal surfaces that were in contact with LSNF;
- calculate the activity of radioactive substances from the evaporated amount of LSNF captured by the filters of the ventilation system;
- determine the activity of radioactive substances released into the environment from the ventilation system.

The assessment made according to this methodology shows that the maximum predicted amount of radioactive substances discharged into the ventilation during LSNF unloading will not exceed $8.73 \cdot 10^4$ Bq. The activity of the radioactive substances coming to the ventilation system from the equipment at the stage of LSNF loading into canisters will be $2.51 \cdot 10^5$ Bq. Taking into account that the air goes through the filtering system with the minimum efficiency of 99 % before being discharged into the atmosphere, we can conclude that the total activity of the release during the procedure implementation will not exceed 3383 Bq, which is less than 1 % of the authorized release limit.

4. Nuclear Safety Analysis

Nuclear safety analysis was performed for the equipment containing the maximum amount of nuclear fissile material. The analyzed equipment included:

- system for discharge and temporary storage of LSNF with filled canisters;
- transport cask with 16 LSNF-filled canisters.

A number of models was developed and effective multiplication factors were calculated to analyze multiplication properties of the media in this equipment units. Geometrical models used in the calculations are shown in Figure 5.

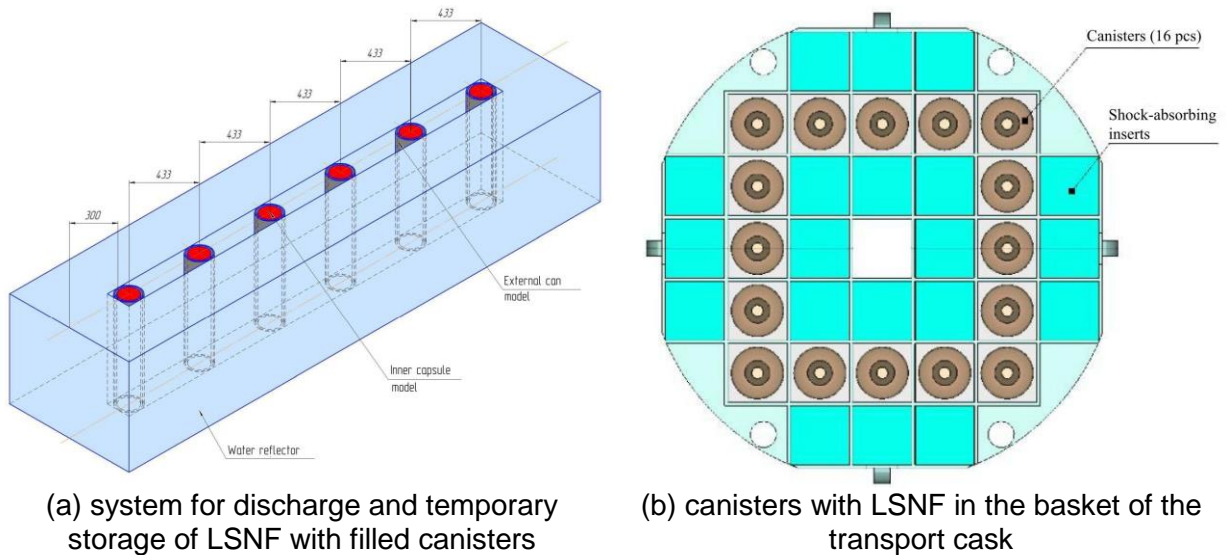

Fig 5. Geometrical models of the equipment media containing the maximum amount of nuclear fissile material

The calculations showed that in normal operation mode the neutron multiplication factor of the medium containing six temporary storage canisters with LSNF was 0.5882 ± 0.0017 . The value of the neutron multiplication factor calculated for an individual transport cask loaded with 16 canisters with LSNF did not exceed 0.444 ± 0.001 .

To justify nuclear safety of the considered procedure under accident conditions, the following initiating events that can affect subcriticality were considered:

- loss of the integrity of the equipment containing LSNF (temporary storage canisters or transport canisters);
- filling the LSNF-containing equipment with water.

Based on the results of the initiating events analysis the corrections in the models related to presence of water and LSNF in the equipment were made. Neutron multiplication factors calculated with the corrected models are given in Table 3.

Initiating event	Neutron multiplication factor	
	Vessels of the system for discharge and temporary storage of LSNF	Transport cask loaded with LSNF-containing canisters
Loss of the integrity of equipment containing LSNF	0.635 ± 0.002	0.559 ± 0.001
Filling the LSNF-containing equipment with water	0.608 ± 0.002	0.501 ± 0.001

Tab 3: Calculated neutron multiplication factors of the media with maximum amount of nuclear fissile material under accident conditions of operation

Thus the results of the calculations show that due to the restrictions to the geometrical dimensions of the equipment with LSNF the nuclear safety criteria are met both in normal operation mode and during development of possible accidents.

5. Severity analysis of probable accident consequences

More than ten accident scenarios have been analyzed in order to assess the severity of accidents that can likely occur while implementing the discussed procedure.

The most severe radiation exposure of the personnel, public and environment will be caused by accidents resulting in a failure of the shielding barriers preventing the spread of ionizing radiation and radioactive substances into the environment, such as:

- loss of the integrity of the containment system (external steel can + internal steel capsule) of the temporary storage canister that result in ingress of the liquid spent fuel into the reactor hall;
- drop of the loaded transfer cask or a canister with LSNF when handling them outside the reactor building.

Simultaneous loss of the integrity of the two shell layers of the temporary storage canister could be caused by hidden defects in the structural materials of the considered equipment or by two independent human errors during installation and testing. The final state of this scenario is LSNF spilled on the floor of the reactor hall. The spillage area was assumed to be 4.5 m². The amount of LSNF evaporated into the air in the reactor hall from the spilled material during the time needed to make a decision concerning a method of the accident elimination (6 hours) was calculated. Using the obtained mass of the evaporated radioactive substances and the nuclear composition of the fission products localized in LSNF the specific activity of the radioactive substances in the air of the accident area was obtained. Moreover assuming the spillage area the LSNF specific activity gamma-radiation dose rates at various distances from the radiation source were calculated. Thus based on the information about the radiation situation in the work area and assumed duration of the accident elimination activities (5 hours) the maximum individual dose was found to be 3.37 mSv for the operator who is equipped with personal protective equipment for the respiratory system and is involved in the elimination activities. This value is comprised of 13.6 μSv due to internal exposure by inhalation of radioactive substances and 3.36 mSv due to external exposure to ionizing radiation.

A drop of the equipment performing localizing functions is possible in case of hidden defects of the structural elements of the transport lugs as well as a human error during handling. The most critical drop in terms of radiation safety is the drop of the equipment containing radioactive substances (loaded transfer cask or a canister with LSNF) in the cask loading area outside the reactor building. To assess severity of the accident consequences the strength analysis of the transfer cask and a canister with LSNF was performed for the case of the drop onto a solid target from the maximum lift height of the equipment during handling. The maximum lift height of the loaded transfer cask is 2 meters, and is achieved when the transfer cask is installed onto the transport cask. The maximum drop height of a canister with LSNF during its loading into the transport cask cell is not more than 1.7 m. The strength analysis of the transfer cask and a canister with LSNF was performed for these heights. The analysis was performed using LS-Dyna software. The analysis also included the nature of the damage to the equipment depending on the drop angle. The models used in the analysis are shown in Fig. 6.

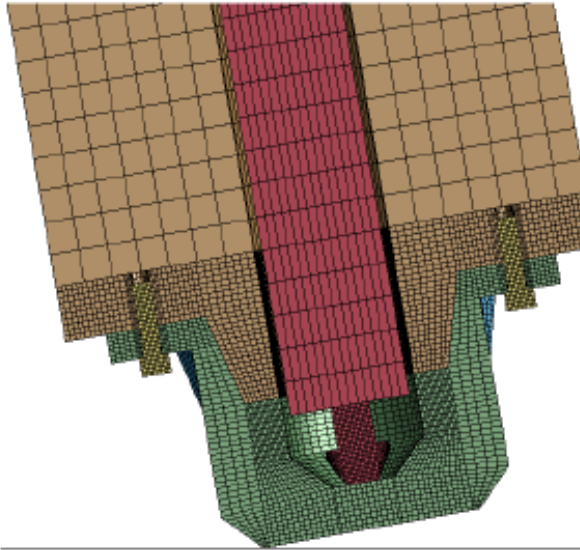

(a) finite element model of the deformation area of the transfer cask in case of its drop

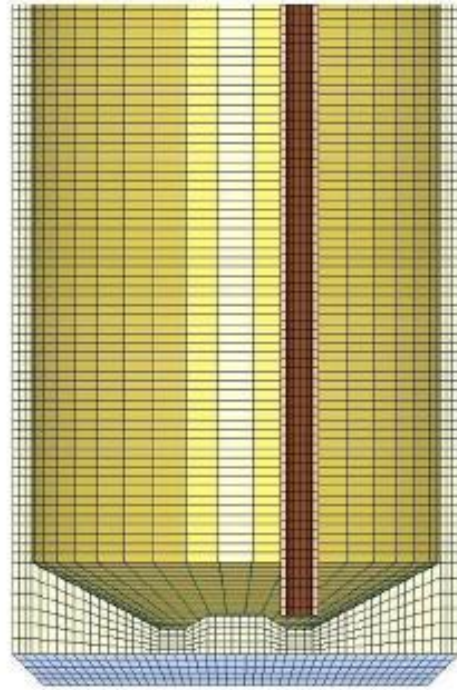

(b) finite element model of the deformation area of the canister with LSNF during its drop into the transport cask cell

Fig 6. The models used to analyze deformations of the transfer cask and the canister with LSNF after the drop

The calculations show that in the worst cases of the confinement equipment drops:

- the transfer cask body maintains its properties to ensure the radiation protection of the personnel;
- the canister with LSNF does not leave the inner space of the transfer cask;
- the canister with LSNF, when dropped on the bottom of the transport cask cell, maintains its integrity and that prevents the release of the LSNF into the inner space of the cask. The deformations of the canister structural elements do not affect the canister removal.

6. Conclusion

The results obtained in the safety analysis of the procedure for IIN-3M LSNF handling and presented in this paper allowed us the following:

- prepare a set of technical measures to ensure radiation safety of the personnel, the public and the environment, that includes additional physical barriers on the way of ionizing radiation and radioactive substances propagation;
- predict radiation situation parameters in the work places during the procedure implementation in various modes of the equipment operation;
- introduce restrictions on the geometrical dimensions of the equipment elements containing fissile materials. These restrictions allowed compliance with nuclear safety requirements during the procedure implementation;
- confirm sufficiency of administrative and technical measures aimed at ensuring nuclear safety during development of accidents.

Applicability of the approaches used in this safety analysis was confirmed by the regulatory authorities of the Republic of Uzbekistan and the Russian Federation, and thus led to obtaining the approval and successfully performing on-site activities in strict compliance with the regulatory requirements applicable on the territory of these countries.